

Class 150 • Outside Screw & Yoke • Bolted Bonnet

Figure 143

- Globe, Flanged

Figure 143½

- Globe, Butt Weld

Size Range:

- 2 through 12 inches
- (50 - 300 mm)

Pressure Temperature Rating

- Carbon Steel
- ASTM A216 Grade WCB
- 285 psi @ -20°F to 100°F
- (20 bar @ -28°C to 37°C)

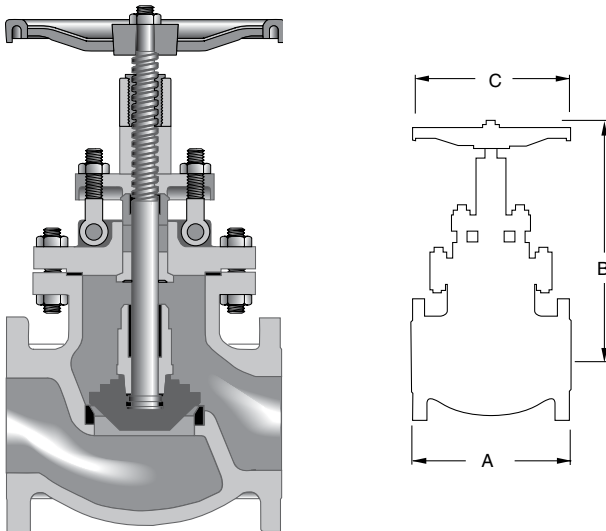

Material of Construction*

Description	Material
Body	ASTM A216 GR.WCB
Seat Ring	ASTM A105N+ Alloy 6 Hardfaced
Disc	ASTM A105N + 13Cr Faced
Disc Thrust Plate	ASTM A276 Type 420
Disc Nut	ASTM A276 Type 410
Stem	ASTM A182 GR.F6a
Bonnet Bolt Nuts	ASTM A194 GR.2H
Bonnet Bolts	ASTM A193 GR.B7
Gasket	304SS + Graphite
Bonnet	ASTM A216 GR.WCB
Bonnet Bushing	ASTM A276 Type 410
Packing Spacer	ASTM A276 Type 410
Stem Packing	Braided Graphite & Die formed Graphite Ring
Eye Bolt Pins	ASTM A29 GR.1045
Gland	ASTM A276 Type 410
Gland Flange	ASTM A216 GR.WCB
Gland Eye Bolts	ASTM A193 GR.B7
Eye Bolt Nuts	ASTM A194 GR.2H
Stem Nut	ASTM A439 GR.D-2
Screw	ASTM A29 GR.1035
Handwheel	ASTM A536 GR.60-40-18
Handwheel Nut	ASTM A29 GR.1045
Washer	ASTM A29 GR.1045
Nameplate	SS304

*Standard construction: WCB-Trim 8, other options are available.
Crane recommends the use of manual or powered gear assistance for sizes 6" and larger.

Industry Standards

Steel Valves	ASME B16.34
Face-to-Face/End-to-End	ASME B16.10
Flange Dimensions	ASME B16.5
Weld End	ASME B.16.25
Testing	API 598
Basic Design	API 623

Dimensions and Weights

Inches (millimeters) - pounds (kilograms)

Valves	2	2 ½	3	4	6	8	10	12	14 ⁽¹⁾	16 ⁽¹⁾
	(50)	(65)	(80)	(100)	(150)	(200)	(250)	(300)	(350)	(400)
A	8.00	8.50	9.50	11.50	16.00	19.50	24.50	27.50	31.00	36.00
(143)	(203)	(216)	(241)	(292)	(406)	(495)	(622)	(698)	(787)	(914)
B	13.90	16.00	15.79	18.23	21.10	24.45	27.99	35.94	44.13	46.61
(Open)	(353)	(406)	(401)	(463)	(536)	(621)	(711)	(913)	(1121)	(1184)
C	7.87	8.00	9.84	11.81	13.78	17.72	17.72	25.20	24.02	24.02
	(200)	(203)	(250)	(300)	(350)	(450)	(450)	(640)	(610)	(610)
Wt.	44.09	70.00	88.18	132.28	224.87	352.74	601.86	928.15	1360.25	1543.24
(143)	(20)	(31)	(40)	(60)	(102)	(160)	(273)	(421)	(617)	(700)
Wt.	37.48	44.09	77.16	103.62	189.60	304.24	482.81	798.07	1082.47	1433.00
(143½)	(17)	(20)	(35)	(47)	(86)	(138)	(219)	(362)	(491)	(650)

(1) Dimensions and weights shown with gear actuator.
 (2) Flanged end and butt-weld valves share same face-to-face dimensions.
 (3) Hammer Blow hand wheels is a standard offering on sizes 8"-16"