

Class 300 • Bolted Cap

Figure 159

- Swing Check, Flanged

Figure 159½

- Swing Check, Butt Weld

Size Range:

- 2 through 24 inches
- (50 - 600 mm)

Pressure Temperature Rating

- Carbon Steel
- ASTM A216 Grade WCB
- 740 psi @ -20°F to 100°F
- (51 bar @ -28°C to 37°C)

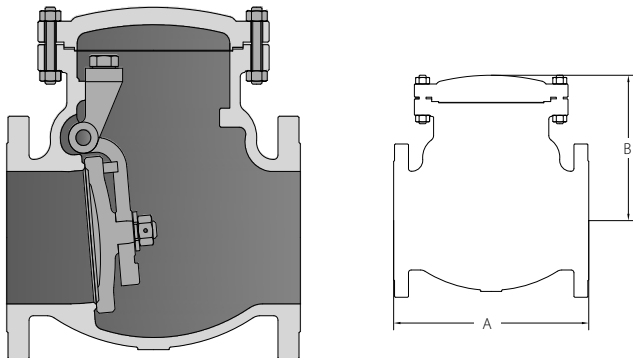

Material of Construction*

Description	Material
Body	ASTM A216 GR.WCB
Seat Ring	ASTM A105N + Alloy 6 Hardfaced
Disc	ASTM A216 GR.WCB + 13Cr Faced
Disc Washer	ASTM A29 GR.1020
Disc Nut Pin	ASTM A276 Type 410
Disc Nut	ASTM A29 GR.1045
Hinge	ASTM A216 GR.WCB
Hinge Pin	ASTM A182 GR.F6a
Bearing Bracket	ASTM A216 GR.WCB
Spring Washer	ASTM A29 GR.1045
Hex Bolt	ASTM A29 GR.1035
Gasket	304SS + Graphite
Cover Bolt	ASTM A193 GR.B7
Cover Bolt Nut	ASTM A194 GR.2H
Cover	ASTM A216 GR.WCB
Eye Bolt	ASTM A181
Nameplate	SS304
Screw	SS304

*Standard construction: WCB-Trim 8, other options are available.

Industry Standards

Steel Valves	ASME B16.34
Face-to-Face/End-to-End	ASME B16.10
Flange Dimensions	ASME B16.5
Weld End	ASME B.16.25
Testing	API 598
Basic Design	API 594

Dimensions and Weights

Inches (millimeters) - pounds (kilograms)

Valves	2	2½	3	4	6	8	10	12	14	16	18	20	24
	(50)	(65)	(80)	(100)	(150)	(200)	(250)	(300)	(350)	(400)	(450)	(500)	(600)
A	10.50	11.50	12.50	14.00	17.50	21.00	24.50	28.00	33.00	34.00	38.50	40.00	53.00
(159)	(267)	(292)	(318)	(356)	(444)	(533)	(622)	(711)	(838)	(864)	(978)	(1016)	(1346)
B	6.97	8.00	9.09	10.47	12.72	15.47	17.87	21.30	23.98	25.71	28.19	27.40	31.34
(Open)	(177)	(203)	(231)	(266)	(323)	(393)	(454)	(541)	(609)	(653)	(716)	(696)	(796)
Wt.	61.73	66.00	97.00	154.32	282.19	445.33	462.97	573.20	1477.10	1763.70	2259.74	2976.24	4303.42
(159)	(28)	(29)	(44)	(70)	(128)	(202)	(210)	(260)	(670)	(800)	(1025)	(1350)	(1952)
Wt.	35.27	48.50	66.14	116.84	222.67	346.13	511.47	912.71	1003.10	1688.74	1706.38	2116.44	3950.68
(159½)	(16)	(22)	(30)	(53)	(101)	(157)	(232)	(414)	(455)	(766)	(774)	(960)	(1792)

(2) Flanged end and butt-weld valves share same face-to-face dimensions.