

# Class 900 • Bolted Cap

**Figure 187**

- Swing Check, Flanged

**Figure 187½**

- Swing Check, Butt Weld

**Size Range:**

- 2 through 12 inches
- (50 - 300 mm)

**Pressure Temperature Rating**

- Carbon Steel
- ASTM A216 Grade WCB
- 2220 psi @ -20°F to 100°F
- (153 bar @ -28°C to 37°C)

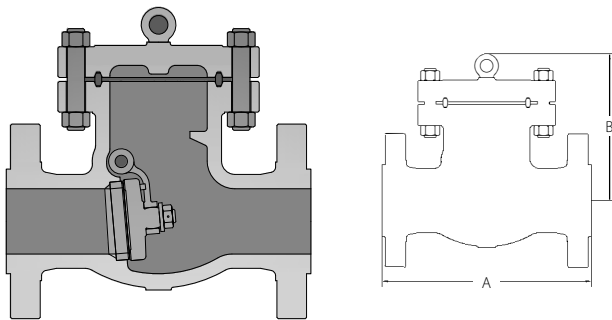

**Material of Construction\***

Description	Material
Body	ASTM A216 GR.WCB
Seat Ring	ASTM A105N +Alloy 6 Hardfaced
Disc	ASTM A216 GR.WCB+13Cr Faced
Disc Washer	ASTM A29 GR.1020
Disc Nut Pin	ASTM A276 Type 410
Disc Nut	ASTM A29 GR.1045
Hinge	ASTM A216 GR.WCB
Hinge Pin	ASTM A182 GR.F6a
Plug	ASTM A276 Type 410
Gasket Ring	Soft Steel
Cover Bolt	ASTM A193 GR.B7
Cover Bolt Nut	ASTM A194 GR.2H
Cover	ASTM A216 GR.WCB
Eye Bolt	ASTM A181
Nameplate	SS304
Screw	SS304

\*Standard construction: WCB-Trim 8, other options are available.

**Industry Standards**

Steel Valves	ASME B16.34
Face-to-Face/End-to-End	ASME B16.10
Flange Dimensions	ASME B16.5
Weld End	ASME B.16.25
Testing	API 598
Basic Design	API 594

**Dimensions and Weights**

Inches (millimeters) - pounds (kilograms)

Valves	2 (50)	3 (80)	4 (100)	6 (150)	8 (200)	10 (250)	12 (300)
A	14.50	15.00	18.00	24.00	29.00	33.00	38.00
(187)	(368)	(381)	(457)	(610)	(737)	(838)	(965)
B	11.18	12.01	11.85	16.65	19.96	22.91	25.59
(Open)	(284)	(305)	(301)	(423)	(507)	(582)	(650)
Wt.	198.42	202.83	308.65	626.11	1113.33	1155.22	2380.99
(187)	(90)	(92)	(140)	(284)	(505)	(524)	(1080)
Wt.	198.42	200.62	308.65	626.11	1113.33	1433.00	1322.77
(187½)	(90)	(91)	(140)	(284)	(505)	(650)	(600)

(2) Flanged end and butt-weld valves share same face-to-face dimensions.