

## Class 125 • Bolted Cap • All Iron • Flanged Ends

### 373 1/2 Check Valve

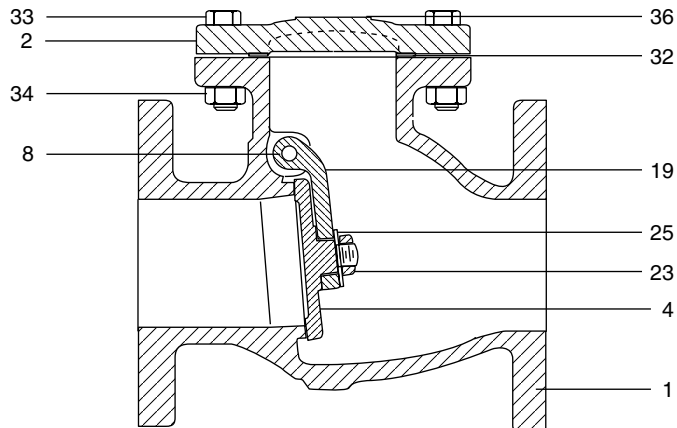

#### Dimensions and Weights Inches (millimeters) - Pounds (kilograms)

Valve Size	Dimensions		WT
	B	M	
2	4.50	8.00	25
	(114)	(203)	(11)
2 1/2	5.38	8.50	30
	(137)	(216)	(13)
3	5.88	9.50	42
	(149)	(241)	(19)
4	6.62	11.50	74
	(168)	(292)	(33)
5	7.75	13.00	100
	(197)	(330)	(45)
6	8.25	14.00	125
	(210)	(356)	(56)
8	10.25	19.50	230
	(260)	(495)	(104)
10	12.00	24.50	440
	(305)	(622)	(200)
12	13.75	27.50	660
	(349)	(699)	(299)
14	16.88	31.00	1060
	(429)	(787)	(481)
16	19.12	36.00	1500
	(486)	(914)	(682)
18	24.00	38.00	1970
	(610)	(965)	(895)
20	27.62	42.00	2590
	(702)	(1067)	(1117)
24	31.00	46.00	3840
	(787)	(1168)	(1745)

#### Materials of Construction

No.	Description	Material	ASTM
1	Body	Cast Iron	A126 Class B
2	Cap	Cast Iron	A126 Class B
4	Disc	Ductile Iron (2" - 4")	A536 Gr. 65-45-12
		Cast Iron (6" - 24")	A126 Class B
6	Seat Ring*	Cast Iron (5", 10" - 24")	A126 Class B
		Cast Iron (2" - 4", 6" - 8") (Integral)	A126 Class B
8	Hinge Pin	Stainless Steel	A276 Type 410
19	Hinge	Ductile Iron	A536 Gr. 65-45-12
20	Disc Stud	Steel (8" - 16")	A108
		Steel (18" - 24")	A108
21	Disc Stud Pin	18-8 Stainless Steel (8" - 16")	
		Steel (18" - 24")	
23	Disc Nut	Steel (8" - 24")	A563 Gr. A
24	Side Plug*	Carbon Steel (2" - 12")	
		Ductile Iron (14" - 24")	A536 Gr. 65-45-12
25	Disc Washer	Carbon Steel (2" - 12")	
26	Lockwasher*	Steel (14" - 24")	
27	Plain Washer*	Steel (14" - 24")	
28	Hinge Pin Bushing*	Carbon Steel (2" - 12")	A108 Gr. 1018
32	Cap Gasket	Aramid Fibers with SBR Binder	
33	Cap Bolt	Carbon Steel	A307 Gr. B
34	Cap Bolt Nut	Carbon Steel	A563 Gr. A
36	Identification Plate	Aluminum	

\* Not shown

See page 5 for Pressure Temperature Ratings

#### Industry Standards

Military Specification: MIL-V-18436

MSS SP-71, Type 1

