

Class 125 • Bolted Bonnet • N-R Stem • Bronze Trim • Flanged

461 Gate Valve

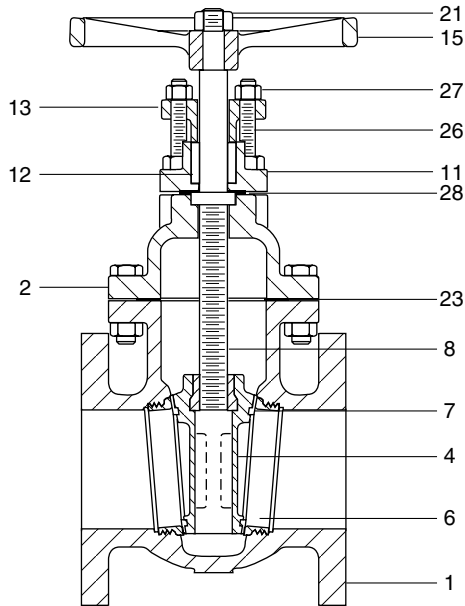

Dimensions and Weights Inches (millimeters) - Pounds (kilograms)

Valve Size	Dimensions			WT
	B	C	M	
2	11.31	8.00	7.00	30
	(287)	(203)	(178)	(14)
2 1/2	12.40	8.00	7.50	40
	(315)	(203)	(191)	(18)
3	13.25	8.00	8.00	56
	(337)	(203)	(203)	(25)
4	16.31	10.00	9.00	90
	(414)	(254)	(229)	(41)
5	18.00	10.00	10.00	126
	(457)	(254)	(254)	(57)
6	20.69	12.00	10.50	152
	(526)	(305)	(267)	(68)
8	24.12	14.00	11.50	260
	(613)	(356)	(292)	(117)
10	33.00	20.00	13.00	490
	(838)	(508)	(330)	(222)
12	36.50	20.00	14.00	672
	(927)	(508)	(356)	(304)
14	40.50	20.00	15.00	968
	(1029)	(508)	(381)	(440)
16	48.00	22.00	16.00	1180
	(1219)	(559)	(406)	(535)
18	50.75	22.00	17.00	1701
	(1289)	(559)	(432)	(772)
20	56.12	24.00	18.00	2188
	(1426)	(610)	(457)	(993)
24	64.00	30.00	20.00	3150
	(1626)	(762)	(508)	(1432)

Materials of Construction

No.	Description	Material	ASTM
1	Body	Cast Iron	A125 Class D
2	Bonnet	Cast Iron	A126 Class B
4	Disc	Bronze (2" - 3")	B584 C84400
		Cast Iron (4" - 24")	A126 Class B
6	Seat Ring	Bronze (2" - 12")	B584 C84400
		Bronze (14" - 24")	B584 C84400
7	Disc Ring	Bronze (4" - 12")	B584 C84400
		Bronze (14" - 24")	B584 C84400
8	Stem	Manganese Bronze (2" - 12")	B584 C86400
		Copper-Silicon Bronze (14" - 24")	
11	Stuffing Box	Ductile Iron (2" - 8")	A536 Gr. 65-45-12
		Cast Iron (10" - 24")	A126 Class B
12	Packing	Braided Flexible Graphite with Corrosion Inhibitor	
13	Gland Flange	Ductile Iron (2" - 8")	A536 Gr. 65-45-12
		Ductile Iron (14" - 24")	A536 Gr. 65-45-12
14	Gland*	Bronze (10" - 12")	B584 C84400
15	Handwheel	Ductile Iron	A536 Gr. 65-45-12
21	Handwheel Nut	Carbon Steel	A563 Gr. A
23	Bonnet Gasket	Aramid Fibers with SBR Binder	
24	Bonnet Bolt*	Carbon Steel	A307 Gr. B
25	Bonnet Bolt Nut*	Carbon Steel	A563 Gr. A
26	Gland Bolt	Carbon Steel	A307 Gr. B
27	Gland Bolt Nut	Carbon Steel	A563 Gr. A
28	Stuffing Box Gasket	Aramid Fibers with SBR Binder	
34	Stuffing Box Bolt*	Carbon Steel	A307 Gr. B
35	Stuffing Box Bolt Nut*	Carbon Steel	A563 Gr. A
55	Gland Follower*	Ductile Iron (10" - 12")	A536 Gr. 65-45-12

* Not shown

See page 5 for Pressure Temperature Ratings

Industry Standards

MSS SP-70, Type 1

