

Class 150 • U-Bolt Bonnet • Rising Stem • All Iron • Threaded

488 Gate Valve

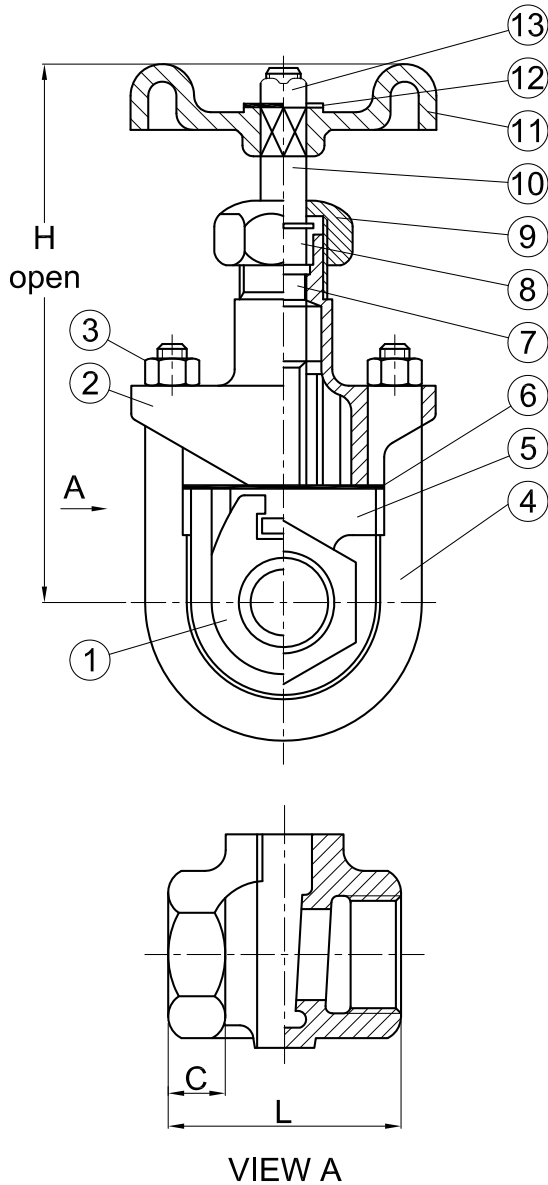

Size	Pressure Rating
1/4 - 2"	225 PSI WOG (Non-Shock)
2 1/2 - 4"	175 PSI WOG (Non-Shock)

Materials of Construction

No.	Description	Material	ASTM
1	Disc	Ductile Iron	A536
2	Bonnet	Ductile Iron	A536
3	Nut	Steel ASTM	A563
4	"U"-Bolt	Steel ASTM	A307
5	Body	Ductile Iron	A536
6	Gasket	Aramid Fiber with Nitrile Binder	
7	Packing	Die-formed Compressed Graphite	
8	Gland	Stainless Steel	A276-410
9	Packing Nut	Ductile Iron	A536
10	Stem	Stainless Steel	A276-410
11	Handwheel	Cast Iron	A126 Gr. B
12	Name Plate	Aluminum	
13	Wheel Nut	Steel	A563 Gr. A

* Not shown
See page 5 for Pressure Temperature Ratings

Industry Standards

MSS SP-70
ASME B16.42

Dimensions and Weights
Inches (millimeters) - Pounds (kilograms)

Valve Size	Dimensions			WT
	H	L	C	
1/4	5.00	2.09	.47	1.50
	(125)	(53)	(11)	(.68)
3/8	5.00	2.09	.47	1.50
	(125)	(53)	(11)	(.68)
1/2	5.00	2.09	.47	1.50
	(125)	(53)	(11)	(.68)
3/4	6.22	2.52	.50	2.0
	(160)	(63)	(12.7)	(.90)
1	7.50	2.63	.63	3.0
	(190)	(67)	(16)	(1.36)
1 1/4	9.00	2.91	.70	5.0
	(228)	(73)	(18)	(2.26)
1 1/2	9.14	3.14	.75	6.5
	(232)	(79)	(19)	(2.94)
2	11.58	3.89	.75	10.0
	(293)	(99)	(19)	(4.53)
2 1/2	12.88	4.59	.91	16.0
	(327)	(116)	(23)	(7.25)
3	14.77	4.92	.91	24.0
	(375)	(124)	(23)	(10.8)
4	19.30	5.93	.98	48.0
	(490)	(150)	(24)	(21.7)