

# Class 900 • Outside Screw & Yoke • Flexible Wedge Disc

**Figure 83**

- Gate, Flanged

**Figure 83½**

- Gate, Butt Weld

**Size Range:**

- 2 through 24 inches
- (50 - 600 mm)

**Pressure Temperature Rating**

- Carbon Steel
- ASTM A216 Grade WCB
- 2220 psi @ -20°F to 100°F
- (153 bar @ -28°C to 37°C)

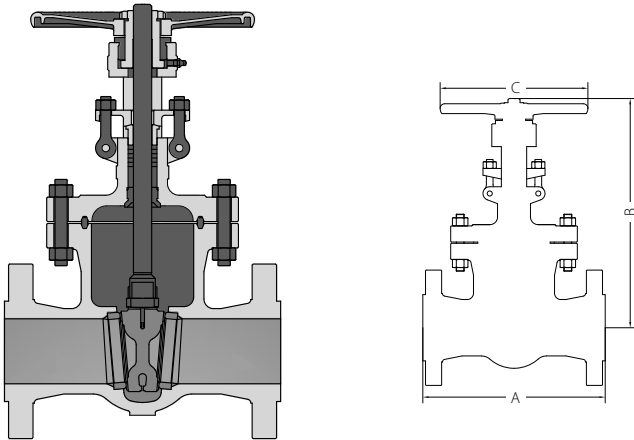

**Dimensions and Weights**

Inches (millimeters) - pounds (kilograms)

| Valves | 2      | 3      | 4      | 6      | 8       | 10      | 12      | 14 <sup>(1)</sup> | 16 <sup>(1)</sup> | 18 <sup>(1)</sup> | 24 <sup>(1)</sup> |
|--------|--------|--------|--------|--------|---------|---------|---------|-------------------|-------------------|-------------------|-------------------|
|        | (50)   | (80)   | (100)  | (150)  | (200)   | (250)   | (300)   | (350)             | (400)             | (450)             | (600)             |
| A      | 14.50  | 15.00  | 18.00  | 24.00  | 29.00   | 33.00   | 38.00   | 40.50             | 44.50             | 48.00             | 61.00             |
| (83)   | (368)  | (381)  | (457)  | (610)  | (737)   | (838)   | (965)   | (1029)            | (1130)            | (1219)            | (1549)            |
| B      | 19.88  | 22.95  | 26.02  | 37.01  | 43.43   | 52.60   | 58.66   | 68.74             | 75.98             | 90.16             | 110.55            |
| (Open) | (505)  | (583)  | (661)  | (940)  | (1103)  | (1336)  | (1490)  | (1746)            | (1930)            | (2290)            | (2808)            |
| C      | 11.81  | 13.78  | 15.75  | 22.05  | 25.20   | 26.77   | 29.92   | 24.02             | 24.02             | 31.89             | 31.89             |
|        | (300)  | (350)  | (400)  | (560)  | (640)   | (680)   | (760)   | (610)             | (610)             | (810)             | (810)             |
| Wt.    | 163.14 | 220.46 | 427.70 | 820.12 | 1404.34 | 2347.92 | 3417.17 | 3487.71           | 5291.09           | 6172.94           | 13448.20          |
| (83)   | (74)   | (100)  | (194)  | (372)  | (637)   | (1065)  | (1550)  | (1582)            | (2400)            | (2800)            | (6100)            |
| Wt.    | 119.05 | 154.32 | 242.51 | 584.22 | 1097.90 | 1785.74 | 2707.28 | 4429.09           | 5650.45           | 7275.25           | 13492.29          |
| (83½)  | (54)   | (70)   | (110)  | (265)  | (498)   | (810)   | (1228)  | (2009)            | (2563)            | (3300)            | (6120)            |

(1) Dimensions and weights shown with gear actuator.

(2) Flanged end and butt-weld valves share same face-to-face dimensions.

**Material of Construction\***

| Description      | Material                                    |
|------------------|---|
| Body             | ASTM A216 GR.WCB                            |
| Seat Ring        | ASTM A105N +Alloy 6 Hardfaced               |
| Disc             | ASTM A216 GR.WCB + 13Cr Faced               |
| Stem             | ASTM A182 GR F6a                            |
| Gasket Ring      | Soft steel                                  |
| Bonnet           | ASTM A216 GR.WCB                            |
| Bonnet Bolts     | ASTM A193 GR.B7                             |
| Bonnet Bolt Nuts | ASTM A194 GR.2H                             |
| Bonnet Bushing   | ASTM A276 Type 410                          |
| Spacer Ring      | ASTM A276 Type 410                          |
| Stem Packing     | Braided Graphite & Die formed Graphite Ring |
| Gland            | ASTM A276 Type 410                          |
| Gland Flange     | ASTM A216 GR.WCB                            |
| Eye Bolt Pins    | ASTM A29 GR.1045                            |
| Gland Eye Bolts  | ASTM A193 GR.B7                             |
| Eye Bolt Nuts    | ASTM A194 GR.2H                             |
| Grease Nipple    | ASTM A29 GR.1020                            |
| Stem Nut         | ASTM A439 GR.D-2                            |
| Retaining Nut    | ASTM A29 GR.1045                            |
| Handwheel        | ASTM A536 GR.60-40-18                       |
| Handwheel Nut    | ASTM A29 GR.1045                            |
| Screw            | ASTM A29 GR.1035                            |
| Bearing          | ASTM A295 GR.52100                          |
| Yoke             | ASTM A216 GR.WCB                            |
| Yoke Bolts       | ASTM A193 GR.B7                             |
| Yoke Bolt Nuts   | ASTM A194 GR.2H                             |
| Nameplate        | SS304                                       |
| Screw            | SS304                                       |

\*Standard construction: WCB-Trim 8, other options are available.

Crane recommends the use of manual or powered gear assistance for sizes 6" and larger.

**Industry Standards**

|                         |              |
|-------------------------|--------------|
| Steel Valves            | ASME B16.34  |
| Face-to-Face/End-to-End | ASME B16.10  |
| Flange Dimensions       | ASME B16.5   |
| Weld End                | ASME B.16.25 |
| Basic Design            | API 600      |
| Testing                 | API 598      |