

# Class 1500 • Outside Screw & Yoke • Flexible Wedge Disc

**Figure 87**

- Gate, Flanged

**Figure 87½**

- Gate, Butt Weld

**Size Range:**

- 2 through 16 inches
- (50 - 400 mm)

**Pressure Temperature Rating**

- Carbon Steel
- ASTM A216 Grade WCB
- 3705 psi @ -20°F to 100°F
- (255 bar @ -28°C to 37°C)

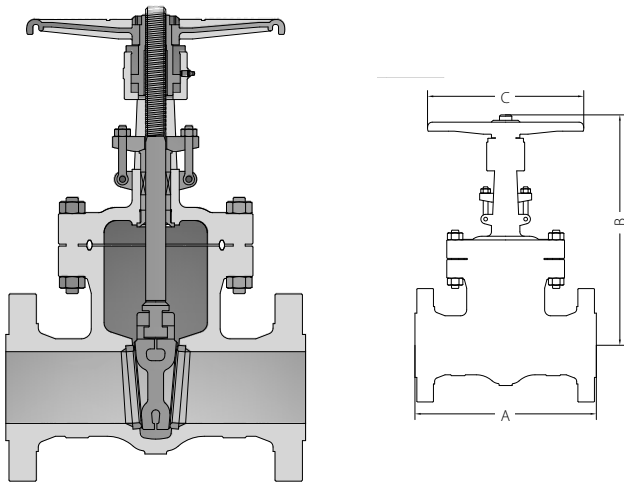

**Material of Construction\***

Description	Material
Body	ASTM A216 GR.WCB
Seat Ring	ASTM A105N + Alloy 6 Hardfaced
Disc	ASTM A216 GR.WCB + 13Cr Faced
Stem	ASTM A182 GR F6a
Gasket Ring	Soft steel
Bonnet	ASTM A216 GR.WCB
Bonnet Bolts	ASTM A193 GR.B7
Bonnet Bolt Nuts	ASTM A194 GR.2H
Bonnet Bushing	ASTM A276 Type 410
Spacer Ring	ASTM A276 Type 410
Stem Packing	Braided Graphite & Die formed Graphite Ring
Gland	ASTM A276 Type 410
Gland Flange	ASTM A216 GR.WCB
Eye Bolt Pins	ASTM A29 GR.1045
Gland Eye Bolts	ASTM A193 GR.B7
Eye Bolt Nuts	ASTM A194 GR.2H
Bearing	ASTM A295 GR.52100
Grease Nipple	ASTM A29 GR.1020
Stem Nut	ASTM A439 GR.D-2
Retaining Nut	ASTM A29 GR.1045
Handwheel	ASTM A536 GR.60-40-18
Handwheel Nut	ASTM A29 GR.1045
Screw	ASTM A29 GR.1035
Yoke	ASTM A216 GR.WCB
Yoke Bolts	ASTM A193 GR.B7
Yoke Bolt Nuts	ASTM A194 GR.2H
Nameplate	SS304
Screw	SS304

\*Standard construction: WCB-Trim 8, other options are available. Crane recommends the use of manual or powered gear assistance for sizes 4" and larger.

**Industry Standards**

Steel Valves	ASME B16.34
Face-to-Face/End-to-End	ASME B16.10
Flange Dimensions	ASME B16.5
Weld End	ASME B.16.25
Basic Design	API 600
Testing	API 598

**Dimensions and Weights**

Inches (millimeters) - pounds (kilograms)

Valves	2	3	4	6	8 <sup>(1)</sup>	10 <sup>(1)</sup>	12 <sup>(1)</sup>	14 <sup>(1)</sup>	16 <sup>(1)</sup>
	(50)	(80)	(100)	(150)	(200)	(250)	(300)	(350)	(400)
A	14.50	18.50	21.50	27.75	32.75	39.00	44.50	49.50	54.50
(87)	(368)	(470)	(546)	(705)	(832)	(991)	(1130)	(1257)	(1384)
B	19.88	24.72	28.94	38.31	45.94	56.69	62.01	74.21	83.70
(Open)	(505)	(628)	(735)	(973)	(1167)	(1440)	(1575)	(1885)	(2126)
C	11.81	15.75	19.69	25.20	21.26	24.02	24.02	31.89	31.89
	(300)	(400)	(500)	(640)	(540)	(610)	(610)	(810)	(810)
Wt.	171.96	370.38	507.06	1203.72	1563.08	2072.35	4982.45	9038.95	13668.66
(87)	(78)	(168)	(230)	(546)	(709)	(940)	(2260)	(4100)	(6200)
Wt.	119.05	284.40	434.31	789.25	1677.72	3615.58	4287.99	7054.79	11684.50
(87½)	(54)	(129)	(197)	(358)	(761)	(1640)	(1945)	(3200)	(5300)

(1) Dimensions and weights shown with gear actuator.  
 (2) Flanged end and butt-weld valves share same face-to-face dimensions.