

**Class 125 • Bronze Cap • Brass/Bronze Disc • Threaded Ends**

**1707 Swing Check Valve**

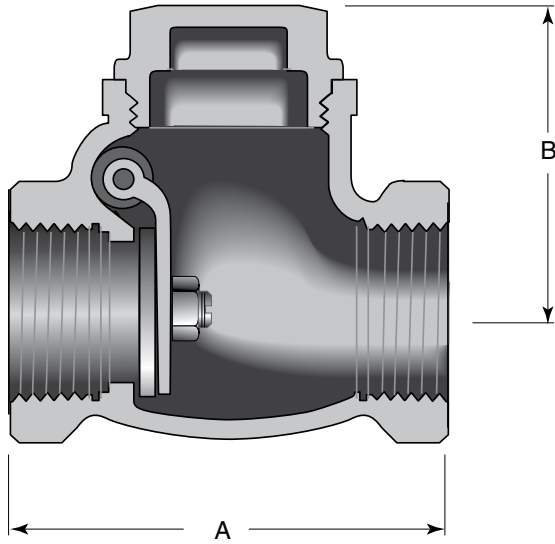

**Materials of Construction**

No.	Description	Material	ASTM Spec.
1	Body	Bronze	B-62 C83600
2	Cap	Bronze	B-16 C83600
3	Disc (1/4" - 3/4")	Bronze	B-16 alloy 360
4	Disc (1" - 3")	Bronze	B-62 C83600

**Caution:** Not recommended for use with reciprocating pumps or air compressors in liquid or gas services. See page 8 for Pressure-Temperature Ratings.

Industry Standards
MSS SP-80, Type 3

**Dimensions and Weights**

Inches (millimeters) - Pounds (kilograms)

Valve Size	Dimensions		Wt.
	A	B	
1/4	2.12	1.50	0.70
	(54)	(38)	(0.32)
3/8	2.12	1.50	0.70
	(54)	(38)	(0.32)
1/2	2.60	1.77	0.80
	(66)	(45)	(0.36)
3/4	2.76	1.93	1.00
	(70)	(49)	(0.45)
1	3.27	2.28	1.40
	(83)	(58)	(0.63)
1 1/4	3.78	2.56	2.70
	(96)	(65)	(1.22)
1 1/2	4.25	2.86	2.90
	(108)	(73)	(1.31)
2	5.04	3.50	4.40
	(128)	(89)	(1.98)
2 1/2	6.30	4.25	7.60
	(160)	(108)	(3.42)
3	7.08	4.84	9.30
	(180)	(123)	(4.19)