

200 CWP • Bronze Cap • Brass/Bronze Disc • Solder Ends

1707S Swing Check Valve

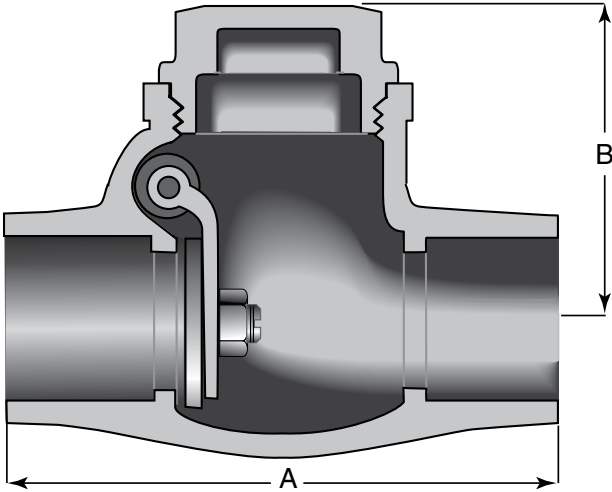

Materials of Construction

No.	Description	Material	ASTM Spec.
1	Body	Bronze	B-62 C83600
2	Cap	Bronze	B-16 C83600
3	Disc (3/8" - 3/4")	Bronze	B-16 alloy 360
4	Disc (1" - 3")	Bronze	B-62 C83600

Caution: Before installing solder-joint valves, be sure solder or brazing alloy melting point is high enough to withstand line pressure, temperature conditions, and is compatible with fluid medium.
See page 7 for Adjusted Pressure-Temperature Ratings.

Caution: Not recommended for use with reciprocating pumps or air compressors in liquid or gas services.

Industry Standards

MSS SP-80, Type 3

Dimensions and Weights

Inches (millimeters) - Pounds (kilograms)

Valve Size	Dimensions		Wt.
	A	B	
3/8	2.28	1.50	0.60
	(58)	(38)	(0.27)
1/2	2.60	1.77	0.80
	(66)	(45)	(0.36)
3/4	3.23	1.93	0.90
	(82)	(49)	(0.41)
1	3.86	2.28	1.40
	(98)	(58)	(0.63)
1 1/4	4.49	2.56	2.50
	(114)	(65)	(1.13)
1 1/2	5.12	2.86	2.80
	(130)	(73)	(1.26)
2	6.14	3.50	4.20
	(156)	(89)	(1.90)
2 1/2	7.25	4.25	7.20
	(184)	(108)	(3.25)
3	8.07	4.84	8.80
	(205)	(123)	(3.97)