

**Class 200 • Union Bonnet\* • SS Plug Type Disc • Thrd. Ends**

**212P Globe Valve**

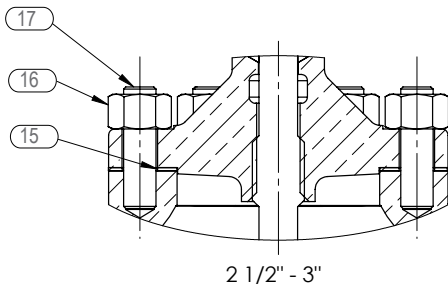
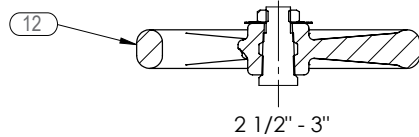
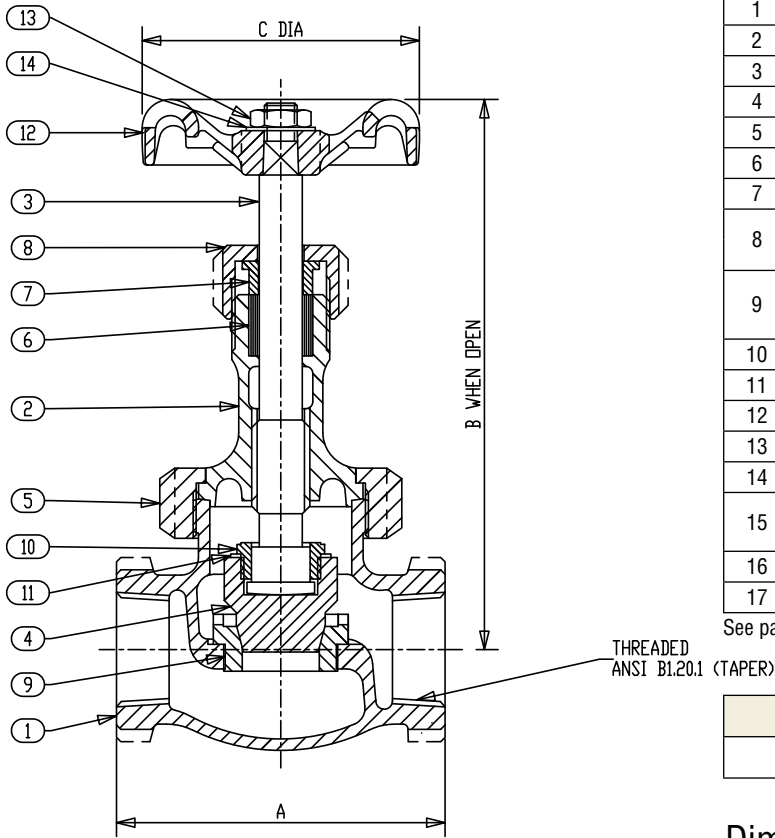

**Materials of Construction**

No.	Description	Material	ASTM Spec.
1	Body	Bronze	B-61 C92200
2	Bonnet	Bronze	B-61 C92200
3	Stem	Copper Silicon Bronze	B-371 C69400
4	Disc	316 Stainless Steel	
5	Union Ring	Bronze	B-62 C83600
6	Packing	Graphite (Asbestos Free)	
7	Gland	Brass	BSEN12164 CW614N
8	Packing Nut	(1/4" - 1 1/2") Brass	BSEN12164 CW614N
		(2" - 3") Bronze	B-62 C83600
9	Body Seat Ring	13% CR Steel	BS970 Pt1 410S21 or BS970 Pt1 431S29
10	Disc Stem Ring	Mang. Bronze	B-371 C69400
11	Lock Washer	Brass	BS2870 - CZ 123
12	Handwheel	Malleable Iron	A-197 F22000
13	Handwheel Nut	Brass	BSEN12164 CW614N
14	ID Plate	Aluminum	
15	Gasket	Synthetic/Glass Fiber with Nitrile Binder	
16	Stud	Steel Cadmium	A-109 C1145
17	Nut	Mild Steel	A-563 Gr-A

See page 8 for Pressure-Temperature Ratings.

Industry Standards
MSS SP-80, Type 3

**Dimensions and Weights**

Inches (millimeters) - Pounds (kilograms)

Valve Size	Dimensions			Wt.
	B	C	A	
1/4	4.80	2.05	2.32	1.24
	(122)	(52)	(59)	(0.56)
3/8	4.80	2.05	2.32	1.24
	(122)	(52)	(59)	(0.56)
1/2	5.51	2.56	2.68	1.76
	(140)	(65)	(68)	(0.80)
3/4	5.98	2.76	3.19	2.73
	(152)	(70)	(81)	(1.24)
1	6.73	3.07	3.74	4.01
	(171)	(78)	(95)	(1.82)
1 1/4	7.60	3.62	4.25	6.02
	(193)	(92)	(108)	(2.73)
1 1/2	8.66	4.06	4.76	8.34
	(220)	(103)	(121)	(3.78)
2	9.88	4.76	5.75	13.30
	(251)	(121)	(146)	(6.03)
*2 1/2	10.98	5.98	7.24	24.04
	(279)	(152)	(184)	(10.9)
*3	12.32	7.00	8.27	36.16
	(313)	(178)	(210)	(16.4)

\*2 1/2" and 3" have Bolted Bonnet