

Class 300 • Union Bonnet • Plug-Type Disc • Renewable SS Seats

384P Angle Valve

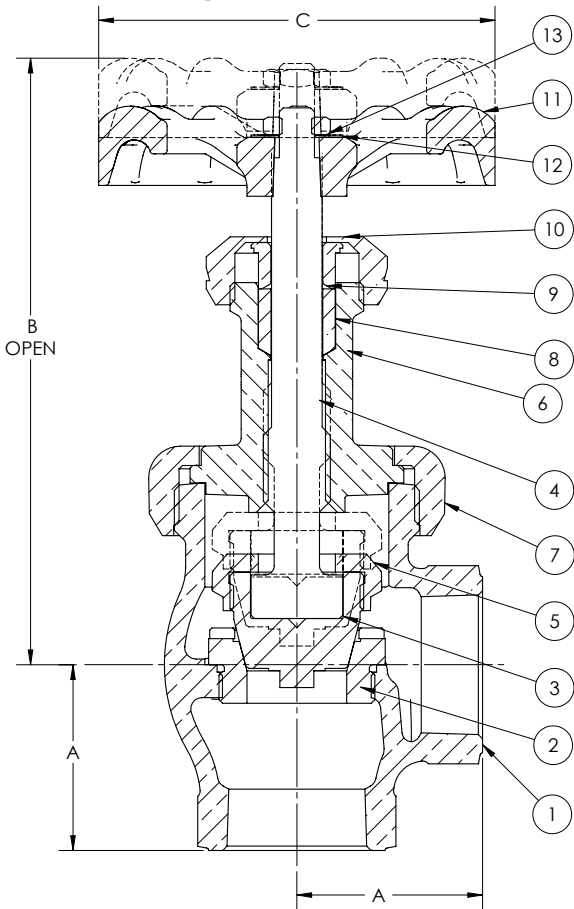

Materials of Construction

No.	Description	Material	ASTM Spec.
1	Body	Bronze	B-61 C92200
2	Body Seat Ring	Stainless Steel	AISI 420 SS
3	Disc	Stainless Steel	AISI 420F SS
4	Stem	Bronze	B-371 C69400
5	Disc Stem Ring	(1/2" - 3/4") Brass	B-16 H02
		(1" - 2") Bronze	B-61 C92200
6	Bonnet	Bronze	B-61 C92200
7	Union Bonnet Ring	Bronze	B-61 C92200
8	Packing	Graphite (Asbestos Free)	
9	Gland	Brass	B-16 H02
10	Packing Nut	(1/2" - 1 1/2") Brass	B-16 H02
		(2") Bronze	B-61 C92200
11	Handwheel	Ductile Iron	
12	ID Plate	Aluminum	
13	Lock Nut	Steel Cadmium	

See page 8 for Pressure-Temperature Ratings.

Industry Standards
MSS SP-80, Type 3

Dimensions and Weights

Inches (millimeters) - Pounds (kilograms)

Valve Size	Dimensions			Wt.
	B	C	A	
1/2	3.97	2.76	1.15	1.32
	(101)	(70)	(29)	(0.60)
3/4	4.83	2.76	1.39	2.16
	(123)	(70)	(35)	(0.98)
1	5.41	4.02	1.64	3.45
	(138)	(102)	(42)	(1.57)
1 1/4	6.38	4.02	2.00	5.21
	(162)	(102)	(51)	(2.37)
1 1/2	6.74	4.02	2.18	6.62
	(171)	(102)	(55)	(3.01)
2	7.13	4.76	2.69	12.32
	(181)	(121)	(68)	(5.60)