

**Class 150 • Threaded Bonnet • Non-Rising Stem • Flanged Ends**

**429 Gate Valve**

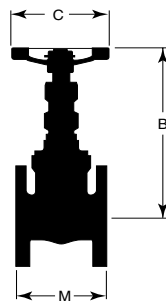
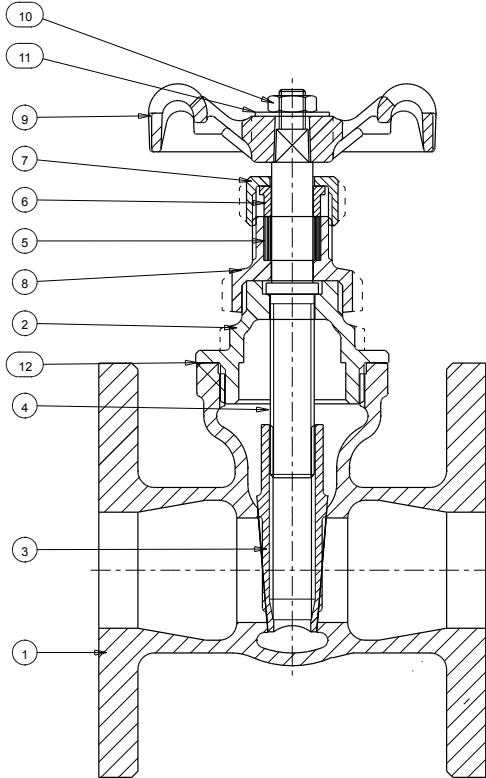

**Materials of Construction**

No.	Description	Material	ASTM Spec.
1	Body	Bronze	B-62 C83600
2	Bonnet	Bronze	B-62 C83600
3	Disc	Bronze	B-62 C83600
4	Stem	Copper Silicon Bronze	B-371 C69400
5	Packing	Graphite (Asbestos Free)	
6	Gland	Brass	BSEN12164 CW614N
7	Packing Nut	Brass	BSEN12164 CW614N
8	Stem Bush	(1") Copper Silicon Bronze	B-371 C69400
8	Stuffing Box	(1 ¼" - 2") Copper Silicon Bronze (2 ½" - 3") Bronze	B-371 C69400 B-62 C83600
9	Handwheel	Malleable Iron	A-197 F22000
10	Handwheel Nut	Brass	BSEN12164 CW614N
11	ID Plate	Aluminum	
12	Gasket	(3" only) Synthetic Glass Fiber Nitrile Filled	

See page 8 for Pressure-Temperature Ratings.

Industry Standards
MSS SP-80, Type 1

**Dimensions and Weights**

Inches (millimeters) - Pounds (kilograms)

Valve Size	Dimensions			Wt.
	B	C	M	
1	4.88	2.75	3.90	5.71
	(124)	(70)	(99)	(2.59)
1¼	5.71	3.63	4.33	6.31
	(145)	(92)	(110)	(2.86)
1½	6.50	3.63	4.72	9.04
	(165)	(92)	(120)	(4.10)
2	7.44	4.06	5.32	12.33
	(189)	(103)	(135)	(5.54)
2 ½	9.13	4.75	6.50	18.50
	(232)	(121)	(165)	(8.39)
3	10.39	6.00	7.28	25.50
	(264)	(152)	(185)	(11.60)