

Class 125 • Threaded Bonnet • PTFE Disc • Threaded Ends

5TF Globe Valve

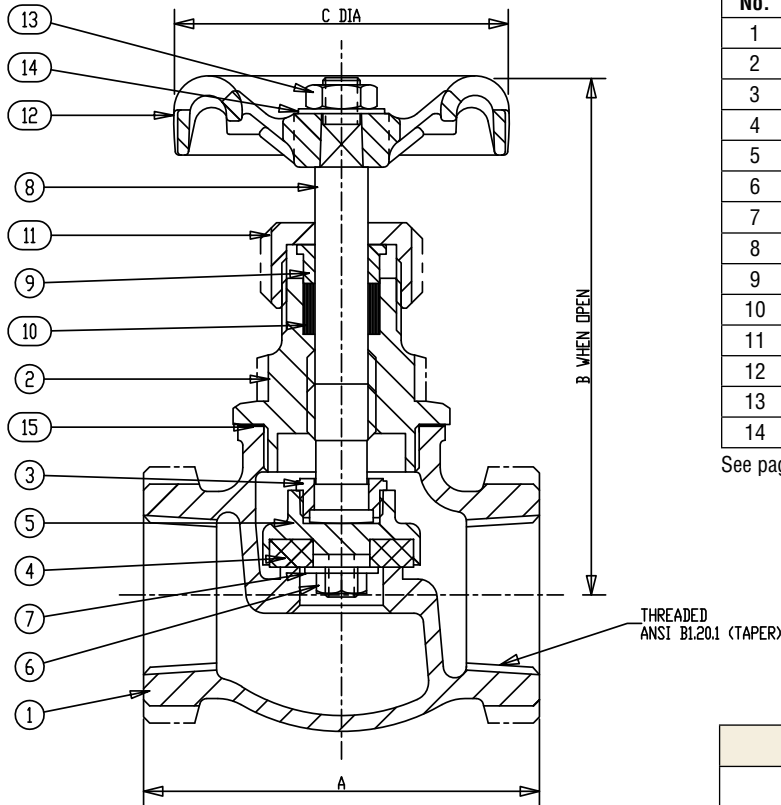

Materials of Construction

No.	Description	Material	ASTM Spec.
1	Body	Bronze	B-62 C83600
2	Bonnet	Bronze	B-62 C83600
3	Disc Stem Ring	Copper Silicon Bronze	B-371 C69400
4	Disc	PTFE (25% Glass Filled)	
5	Disc Holder	Bronze	B-62 C83600
6	Disc Ret Nut	Brass	BSEN12164 CW614N
7	Washer (2½ - 3")	Brass	BSEN12164 CW614N
8	Stem	Copper Silicon Steel	B-371 C69400
9	Gland	Brass	BSEN12164 CW614N
10	Packing	Graphite (Asbestos Free)	
11	Packing Nut	Brass	BSEN12164 CW614N
12	Handwheel	Malleable Iron	A-197 F22000
13	Handwheel Nut	Brass	BSEN12164 CW614N
14	ID Plate	Aluminum	

See page 8 for Pressure-Temperature Ratings.

Industry Standards
MSS SP-80, Type 2

Dimensions and Weights
Inches (millimeters) - Pounds (kilograms)

Valve Size	Dimensions			Wt.
	A	B	C	
¾	2.99	4.55	2.98	1.90
	(76)	(116)	(76)	(0.86)
½	1.94	3.66	1.96	0.70
	(49)	(93)	(50)	(0.32)
¾	2.57	3.55	2.14	1.10
	(65)	(90)	(54)	(0.48)
1	3.51	5.01	3.03	2.80
	(89)	(127)	(77)	(1.25)
1 ¼	3.88	5.10	3.70	4.10
	(99)	(130)	(94)	(1.86)
1 ½	4.67	6.05	4.63	6.20
	(119)	(154)	(118)	(2.79)
2	5.75	6.74	5.24	9.80
	(146)	(171)	(133)	(4.45)